

Normas de Referência

Construção

BSI BS EN ISO 17292
ASME B16.34

Testes

API 598

Conexões

ROSCA BSP - ISO 228
ROSCA NPT - ANSI/ASME 1.20.1
SOLDA SW - ASME B16.11
SOLDA BW - ASME B16.25

Materiais

Corpo e Tampas

ASTM A 216 - WCB
ASTM A 351 - CF8
ASTM A 351 - CF8M

Esfera

ASTM A 351 - CF8
ASTM A 351 - CF8M
ASTM A 217 - CA 15
ICI 416
ASTM B16 - C360

Vedações

PTFE
COMP L

Haste

ASTM A 276 - 304
ASTM A 276 - 316
SAE 1020
ASTM A 276 - 410
ASTM A 582 - 416



Desenho Técnico

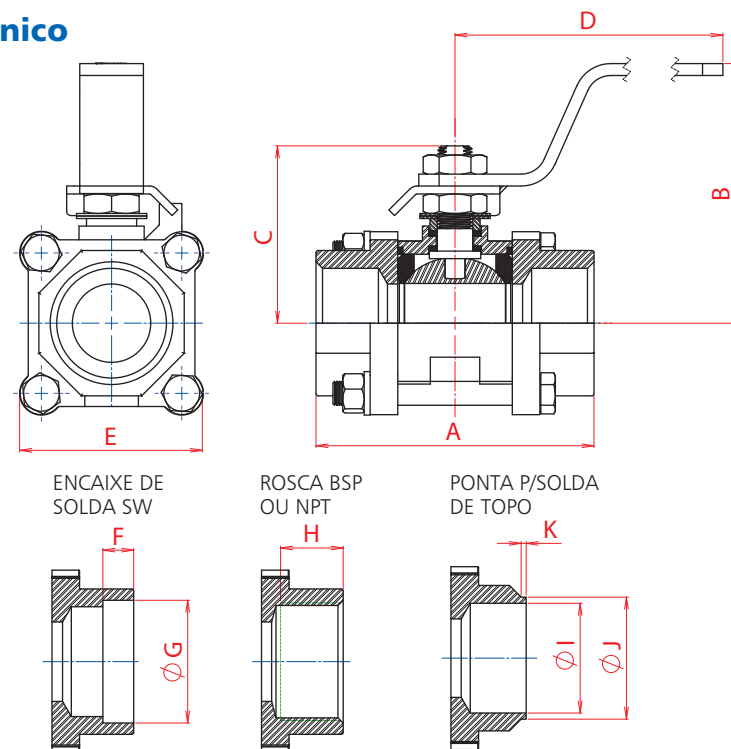

TIPOS DE CONEXÕES

ENCAIXE DE SOLDA SW

ROSCA BSP OU NPT

PONTA P/SOLDA DE TOPO

VÁLVULA DE ESFERA TRIPARTIDA PASSAGEM REDUZIDA (PR)															
BITOLA		PASS.	A*	B	C	D	E	F	G	H	I	J	K	PESO kg	Coeficiente de Fluxo Kv (m³/h)
POL.	DN														
1/2"	15	11,1	62,0	46,0	39,0	125,0	44,0	9,5	21,8	17,0	15,8	21,8	2,0	0,49	5,0
3/4"	20	14,0	71,6	48,0	41,0	125,0	48,0	12,5	27,1	17,0	20,9	27,1	2,0	0,61	9,8
1"	25	20,4	88,6	82,0	51,0	165,0	57,0	12,5	33,8	23,0	26,4	33,8	2,0	1,05	18,7
1.1/4"	32	25,4	101,0	86,0	60,0	165,0	64,0	12,5	42,6	23,0	35,0	42,6	2,0	1,40	42,0
1.1/2"	40	31,7	111,7	110,0	73,0	170,0	73,0	12,5	48,7	28,0	41,0	48,7	3,0	2,20	72
2"	50	38,0	121,5	113,0	77,0	170,0	82,0	16,0	61,0	28,0	52,5	61,0	3,0	2,90	107
2.1/2"	65	50,8	138,8	125,0	86,0	256,0	94,0	16,0	73,8	28,0	62,7	73,8	3,0	4,65	185
3"	80	63,0	176,5	145,0	116,0	267,0	116,0	16,0	90,1	37,0	78,0	90,1	3,0	8,70	305

VÁLVULA DE ESFERA TRIPARTIDA PASSAGEM PLENA (PP)															
BITOLA		PASS.	A*	B	C	D	E	F	G	H	I	J	K	PESO kg	Coeficiente de Fluxo Kv (m³/h)
POL.	DN														
1/4"	8	11,1	62,0	46,0	39,0	125,0	44,0	9,5	14,0	11,0	9,3	14,0	2,0	0,54	5,0
3/8"	10	11,1	62,0	46,0	39,0	125,0	44,0	9,5	17,6	11,0	12,3	17,6	2,0	0,52	5,0
1/2"	15	14,0	71,5	48,0	41,0	125,0	48,0	9,5	21,8	17,0	15,8	21,8	2,0	0,65	14,6
3/4"	20	20,4	88,6	82,0	51,0	165,0	57,0	12,5	27,1	17,0	20,9	27,1	2,0	1,13	27,8
1"	25	25,4	101,0	86,0	60,0	165,0	64,0	12,5	33,8	23,0	26,4	33,8	2,0	1,60	56,5
1.1/4"	32	31,7	111,7	110,0	73,0	170,0	73,0	12,5	42,6	23,0	35,0	42,6	2,0	2,55	104
1.1/2"	40	38,0	121,5	113,0	77,0	170,0	82,0	12,5	48,7	28,0	41,0	48,7	3,0	3,30	161
2"	50	50,8	138,8	125,0	86,0	256,0	94,0	16,0	61,0	28,0	52,5	61,0	3,0	5,20	278
2.1/2"	65	63,0	176,5	145,0	116,0	267,0	116,0	16,0	73,8	28,0	62,7	73,8	3,0	9,38	460

A vazão apresentada em Kv (m³/h) corresponde a um diferencial de pressão (Δp) de 1 bar utilizando água como fluido de teste.

* Para conexão BW, medidas sob consulta.

Especificações Técnicas

Válvula de bloqueio de fluxo Classe 300 indicada para utilização em diversos líquidos, gases e vapores em ampla faixa de temperatura e pressão conforme norma ASME B16.34.

Construção tripartida (um corpo e duas tampas), facilitando a manutenção sem a necessidade de desconectar as extremidades da linha.

Haste à prova de expulsão.

Disponível na construção com dupla vedação, o que proporciona maior segurança quando utilizadas em linha de vapor.

De fácil aplicação para trava de cadeado.